



Sanitary  
flow  
equipment



Quality  
System  
Certified  
ISO 9001

VSS-seat.doc  
Rev.00 Page 1 of 1

## TFM™ as a seating material for High Purity Valves

AR Inox High Purity ball valves utilize Dyneon™ TFM 1600 PTFE as a standard seating material

### What is TFM™ ?

TFM is chemically modified PTFE that fills the gap between conventional PTFE and melt-processable PFA according to ASTM D 4894 and ISO Draft WDT 539-1.5, TFM is classified as a PTFE.

TFM-PTFE is a second-generation modified polytetra-fluoro-ethylene (PTFE) that maintains the exceptional chemical and heat resistance properties of conventional PTFE, but with significantly lower melt viscosity.

This property results in better particle fusion during sintering and much smoother ball-to-seat sealing surfaces

TFM 1600 PTFE are ideal for ball valves in high purity applications. In addition, TFM complies with :

- 3A Sanitary standard for multiple-use plastic materials used as product contact surfaces for dairy equipment.
- FDA-21 CFR 177.1550 direct contact with meat or poultry food products prepared under FDA inspection.
- USP23, biological test for plastic Class VI

**TFM 1600 PTFE**  
for steam service  
code **KIT-VSSV**



cavity filled seat  
**TFM 1600 PTFE**  
for high purity applications  
code **KIT-VSS**

## Spare Parts KIT

Code **KIT-VSS / VSSV**

<b>5</b>	2 seat	TFM™ 1600 PTFE
<b>6</b>	2 o-ring seat	Viton
<b>7</b>	2 o-ring heads	Viton
<b>8</b>	2 o-ring stem	Viton
<b>9</b>	2 stem guide bushing	PTFE + 25% glass
<b>10</b>	1 elastic ring	AISI 304 stainless steel

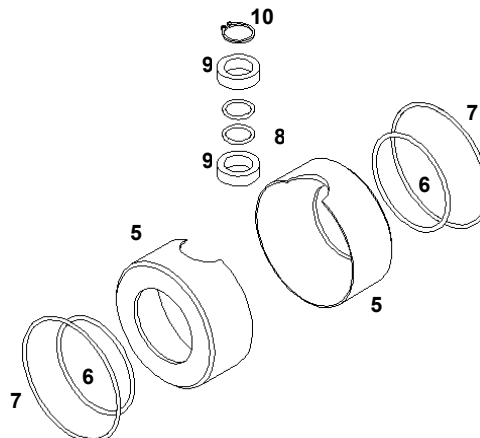
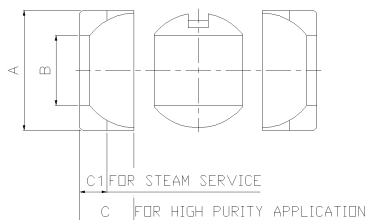

Code / Size		Dimensions mm			
BS Code	Compatible	A	B	C	C1
KIT-VSS / VSSV ½"	-	32,0	9,80	12,9	-
KIT-VSS / VSSV ¾"	DN15	32,0	15,0	12,6	-
KIT-VSS / VSSV 1"	DN25	45,0	22,1	19,9	13,1
KIT-VSS / VSSV 1" ½	DN40	60,0	34,8	27,1	16,1
KIT-VSS / VSSV 2"	DN50	80,0	47,5	33,0	18,0
KIT-VSS / VSSV 2" ½	DN65	97,0	60,1	-	18,0
KIT-VSS / VSSV 3"	-	119,8	72,6	-	20,0
KIT-VSS / VSSV	DN80	119,8	75,0	-	20,0
KIT-VSS / VSSV 4"	DN100	155,0	97,6	-	25,0

They are obtained, by means of machining on CCN, from **TFM™ 1600 PTFE** round bar, Poly-Tetra-Fluor-Ethylene from Dyneon™ - 3M.

**OPERATING PRESSURE** Minimum Full Vacuum @ Maximum 30 bar g.

**OPERATING TEMPERATURE** Continuous use : Min. - 10 °C @ Max. 150 °C

In the interests of development and improvement of the product, we reserve the right to change the specifications without prior notice.