



Sanitary
flow
equipment

Quality
System
Certified
ISO 9001



VSS-TB-BW TANK BOTTOM dimensions.doc
Rev.00 Page 1 of 1

VSS-TB-BW Tank Bottom ball valve welded body

The "TB" Series Flush Tank ball valve incorporates all the advantages of VSS Available in different executions, may be fit at the tank bottom by welding plate or TK-Connection; for special applications on existing reactors, we also manufactures special adaptor plates in order to accommodate customer request. The special design of the welding plate, is an integral welded part of the tank surface and preventing stagnation of the media.

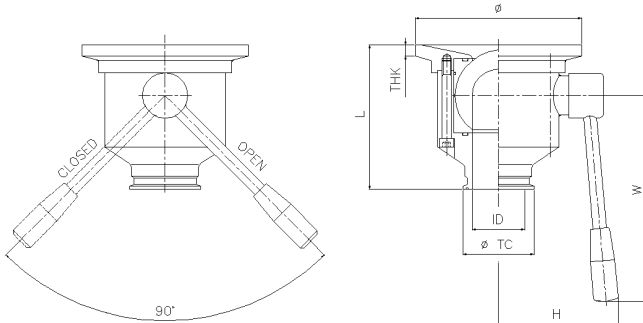

Flush Tank Ball Valve advantages over conventional Flush Tank

- Higher CV
- Full bore, no pressure drop
- Simple quarter-turn opening
- Ease maintenance operation

Dimensions table

CODE	DN	ØTC	ID	L	H	W	Ø	Thk
VSS 1"-TB-BW	25	50,4	22,1	95	72	155	100	8
VSS 1"1/2-TB-BW	40	50,4	34,8	120	85	185	100	8
VSS 2"-TB-BW	50	64	47,5	140	95	185	150	10
VSS 2"1/2-TB-BW	65	77,4	60,2	150	100	245	150	10
VSS 3"-TB-BW	80	90	72,9	170	115	245	220	15
VSS 4"-TB-BW	100	118,8	97,6	210	155	370	250	20

Special executions available on request :

Welding plate with radius or bigger different thickness, extended tube for orbital welding.

For special applications, we manufactures special adaptor plates, when replacing a conventional flush tank valve, with a flush tank ball valve and also to ship the plate independently from the valve, in order to accommodate customer requests.

Welding Instructions

1. With the valve in it's open position, remove body connector screws.
2. Separate the upstream flush tank end and the down stream end.
3. Dispose the used O-rings seals.
4. Place all components removed in clean secure position, clear of welding splatter.
5. Prepare the vessel port at the desired location according to the dimension of the flush tank end. Remember: it is crucial to have maximum adaptation (minimum gap) between the vessel bore and the flush tank end.
6. Fit the flush tank end to the bottom of the reactor, with the internal surface of the vessel in line with the surface of the flush tank end, Tack weld only. (See figure).
7. Protect the sealing surface of the flush tank end from welding splatter and complete welding. Allow enough time for cooling.
8. Flush the tank allowing dirt, welding slag, or any other debris to be flushed through the flush bottom tank end.
9. Replace body seals (replacement package).
10. Lift the complete assembly to engage the flush tank end.
11. Position the screws and turn (2-3 turns) so the complete assembly is connected loosely in place.
12. Tighten the bolts to torque figures, according to tightening patterns.
13. Close the valve and run the process.

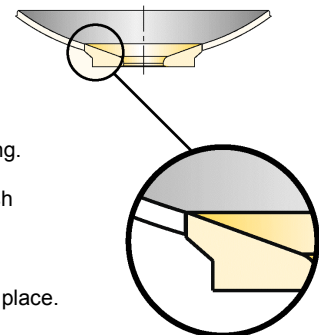

Get the information you need and more at : info@erreinox.it

In the interests of development and improvement of the product, we reserve the right to change the specifications without prior notice.