



# Tank bottom aseptic valve



# VFA10° TANK BOTTOM VALVES

## RADIAL SEATED DIAPHRAGM

Designed for pharmaceutical and biopharmaceutical applications, the radial seated diaphragm valves combines the best features of a piston valve with the inherent cleanability of a standard flat diaphragm valve.

## Aseptic design for pharmaceutical applications

All materials of construction conform to FDA and cGMP requirements.

The valve housing and the piping connections are self draining without dead-legs.

All moving parts in the actuator are completely isolated from contact with the process.

**Available sizes** 1”(25,4), 1 1/2” (38,1), 2” (50,8), 3” (76,2), 4” (101,6).

**Pressure directive** The body are designed according to PED Directive 97/23/EC for Europe, ASME VIII Div.2 for US and F.E.M. (Finite Element Method) calculated, approved and certified by notified body. The valve body is machined from solid round bar in AISI 316L 1.4404 as standard, having other materials 1.4435 or hastelloy available upon request w/certs/heat #

**Extra equipment** available on request

- Customized welding plate
- Proximity switch for indication of open/closed valve position
- Adjustable flow regulator
- CIP / SIP connection
- integrated SIP satellite valve
- Assembling tightening tool for locking ring

The diaphragms are available in Silicone and TFM 1600 PTFE comply with FDA and USP Class VI regulations

The welding pad of the body is to be welded flush to the bottom vessel, result as an integral part of the tank surface for preventing stagnation of the media.

The outlet connection is flush to the diaphragm to minimize hold-up volume, the standard outlet connection on the valve body is furnished on a 45° angle to the horizontal with an ASME-BPE ferrule, Other optional end connections upon request include ISO/DIN connections. 45° angle outlet facilitate the ease of fit-up and permit using standard tubing to connect

upon request Steam and CIP ports can be fabricated to the valve body providing access to the internal contact surfaces, of the valve as well as downstream piping

Available with manual thermoplastic handwheel ergonomically designed to provide ease of operation or the new thermoplastic pneumatic actuators NC spring return, as standard for general purpose use. Stainless steel handwheel or pneumatic actuators, are available upon request.

The method of attachment for both the manual and automatic bonnet assemblies is through the use of a bonnet adapter ring which is easily tightened or loosened utilizing standard spanner wrenches facilitating ease of maintenance.

The NAMUR connection for the control valve is provided as standard

FOR HYDRO TEST....

A blank cap will eventually be sold as an option to replace the topworks during hydro testing of the tank. This will protect the purity of the diaphragm for the system can be quite dirty during the tank hydro test.

A bright red indicator provides positive indication of closed and open position, standard for all actuators. The pneumatic actuators come with a wide variety of accessories as mechanical or inductive control box and manually adjustable flow regulator, pilot valve....

10°

The 10° vertical offset enhances drainability while minimizing the internal sump within the vessel No problem associated with static material and cleaning or sterilizing

## VFA10° - S/TC Flush Tank Bottom welded body

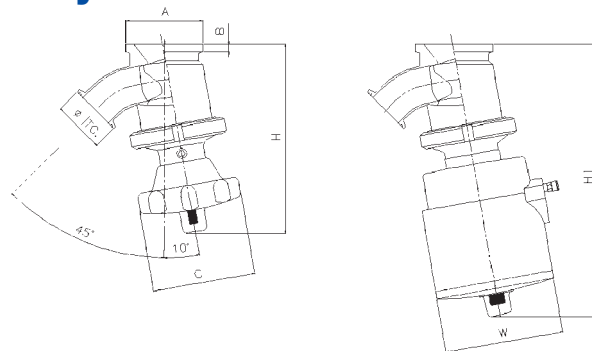

Dimensions table

CODE	INCH	DN	ØTC	ID	A	B	C	H	W	H1
VFA10°-S/TC1"	1"	25	50,4	22,1	60	8	100	175	85	220
VFA10°-S/TC1"1/2	1" 1/2	40	50,4	34,8	75	8	100	185	116	270
VFA10°-S/TC2"	2"	50	64	47,5	115	10	100	200	140	330
VFA10°-S/TC3"	3"	80	90	72,9	125	12	100	260	140	350
VFA10°-S/TC4"	4"	100	118,8	97,6	170	15	150	340	170	400

## VFA10° - TK/TC TK Connection removable body

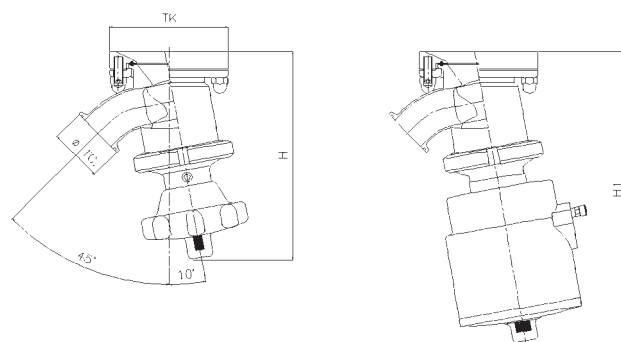

Dimensions table

CODE	ØTC	ID	TK	ØTK	H	H1
VFA10°-TK/TC1"	50,4	22,1	2"	100	190	240
VFA10°-TK/TC1"1/2	50,4	34,8	2"1/2	112	200	280
VFA10°-TK/TC2"	64	47,5	4"	170	220	350
VFA10°-TK/TC3"	90	72,9	4"	170	270	380
VFA10°-TK/TC4"	118,8	97,6	Not available for TK-Conn application			

## Net volume of valve body cavity with PTFE diaphragm installed

Tank bottom valve body available in the following type :

VFA10°-S/TC

10° Angled butt weld

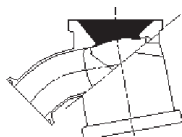

VFA10°-TK/TC

Angled TK removable body

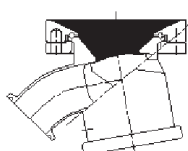

VFA- S/TC

Flanged flush weld



VFA- FL/TC

Flanged removable body

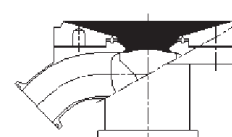

Dimensions table

Valve Code/Size	INCH	DN	VFA10°-S/TC	VFA10°-TK/TC	VFA- S/TC	VFA- FL/TC
VFA10°-S/TC1"	1"	25	14	50	25	30
VFA10°-S/TC1"1/2	1" 1/2	40	27	72	75	105
VFA10°-S/TC2"	2"	50	92	235	85	150
VFA10°-S/TC3"	3"	80	170	310	320	Not available
VFA10°-S/TC4"	4"	100	Not standard product, available on specific request only			

## VFA - S/TC Flush Tank Bottom welded body

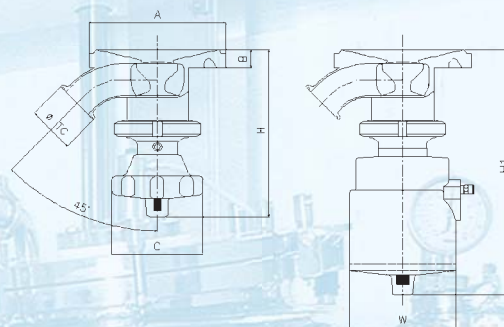

Dimensions table

CODE	ØTC	ID	A	B	C	H	W	H1
VFA-S/TC1"	50,4	22,1	100	15	100	165	85	230
VFA-S/TC1"1/2	50,4	34,8	150	20	100	180	116	270
VFA-S/TC2"	64	47,5	180	20	100	200	140	330
VFA-S/TC3"	90	72,9	200	35	100	270	140	350
VFA-S/TC4"	118,8	97,6	Available on request only					

## VFA - FL/TC Flanged body removable

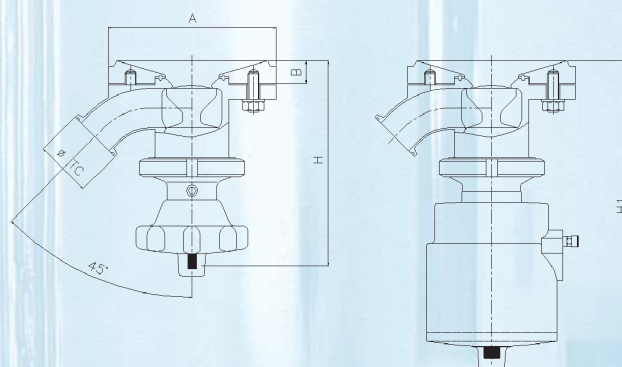

Dimensions table

CODE	INCH	DN	ØTC	ID	A	B	H	H1
VFA-FL/TC1"	1"	25	50,4	22,1	100	15	175	240
VFA-FL/TC1"1/2	1" 1/2	40	50,4	34,8	150	20	190	285
VFA-FL/TC2"	2"	50	64	47,5	180	20	205	345
VFA-FL/TC3"	3"	80	90	72,9	200	35	275	370
VFA-FL/TC4"	4"	100	118,8	97,6	Available on request only			

Special executions available on request:

- welding plate with radius or bigger different thickness, special adaptors plate
- 45°Outlet port butt weld
- Stainless steel handle/pneumatic actuator
- Adjustable flow regulator
- Mechanical/inductive control box

## VFA - FL/O - Ring Flanged body removable

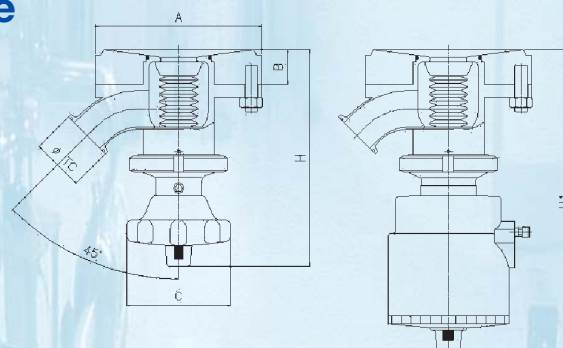

Dimensions table

CODE	INCH	DN	ØTC	P max	A	B	H	H1
VFA-FL/TC1"	1"	25	50,4	7,5 bar	100	15	175	240
VFA-FL/TC1"1/2	1" 1/2	40	50,4	7,5 bar	150	20	190	285
VFA-FL/TC2"	2"	50	64	7,0 bar	180	20	205	345
VFA-FL/TC3"	3"	80	90	3,0 bar	200	35	275	370
VFA-FL/TC4"	4"	100	118,8	97,6	Available on request only			

The new Tank Bottom valves "flush wall execution" Radial seated diaphragm valve with unique O-Ring seal design minimizes bacteria traps all your problems with high viscosity products

# VFA10° VALVE BODY Tank Bottom Valve - INFORMATION

**Design temperature, valve body:** -80°C to 200°C (-112°F to 392°F)  
**Design pressure, valve body:** -1 bar to 10 bar (-14,5 psi to 101,5 psi)

The valve body are designed according to PED Directive 97/23/EC for Europe, ASME VIII Div.2 for US and F.E.M. (Finite Element Method) calculated, approved and certified by notified body.  
 Warning : The applied diaphragm and actuator may have a different design temperature and/or pressure.  
 The weakest part in the assembled product set the final, permitted design temperature and pressure limits.

## Flow rate

In order to design valves for a process system correctly, the valve size is determined by the required flow rate. The Kv-value serves as a calculation basis for the different process conditions. This value is stated in the following table with regard to nominal diameter and standards.

## Kv-value (m3/h)

The Kv-value is a parameter defining the flow rate of valves. It describes the amount of water from 5° to 25°C which flows through the valve at a pressure loss of 1 bar when the valve is 100% open

## Conversion

For the correct Kv to Cv conversion calculation, use only the stated units formulas above.

The Kv-value must be converted from (cubic meter/hour) by utilizing the following conversion factor.

In the US the flow rate of water is measured with the Cv-value in US-gallons per minute (gpm) with a pressure drop of 1 PSI.

conversion of Kv to Cv  $Cv = 1,17 \times Kv$   
 conversion of Cv to Kv  $Kv = 0,86 \times Cv$

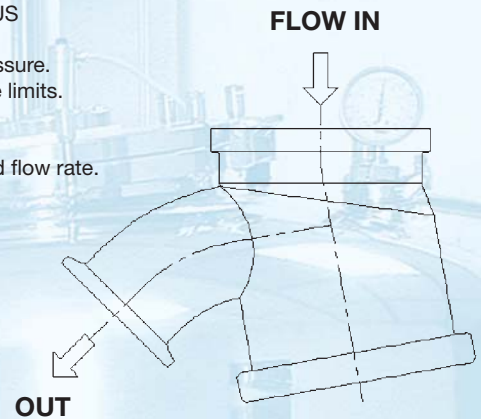

Flow characteristics with TFM 1600 PTFE diaphragm installed (Flow In to Out)

Valve Code/Size	INCH	DN	Kv-value (m3/h)	Cv-value (gpm)
VFA10°-S/TC1"	1"	25	10,5	12,2
VFA10°-S/TC1"	1" 1/2	40	15,0	17,5
VFA10°-S/TC2"	2"	50	32,0	37,4
VFA10°-S/TC3"	3"	80	78,0	91,2
VFA10°-S/TC4"	4"	100	Not standard product, available on specific request only	

## Available configurations

### STANDARD DESIGN

The valves is composed of three following main parts:

- **Actuator** - either manual or pneumatic
- **Diaphragms** - available in Silicone and TFM
- **Valve body** - in line, zero static, tank bottom

The modular design ensures a wide flexibility and you can combine the three parts in almost any combination.

The manual / pneumatic actuators and body are assembled by a locking ring

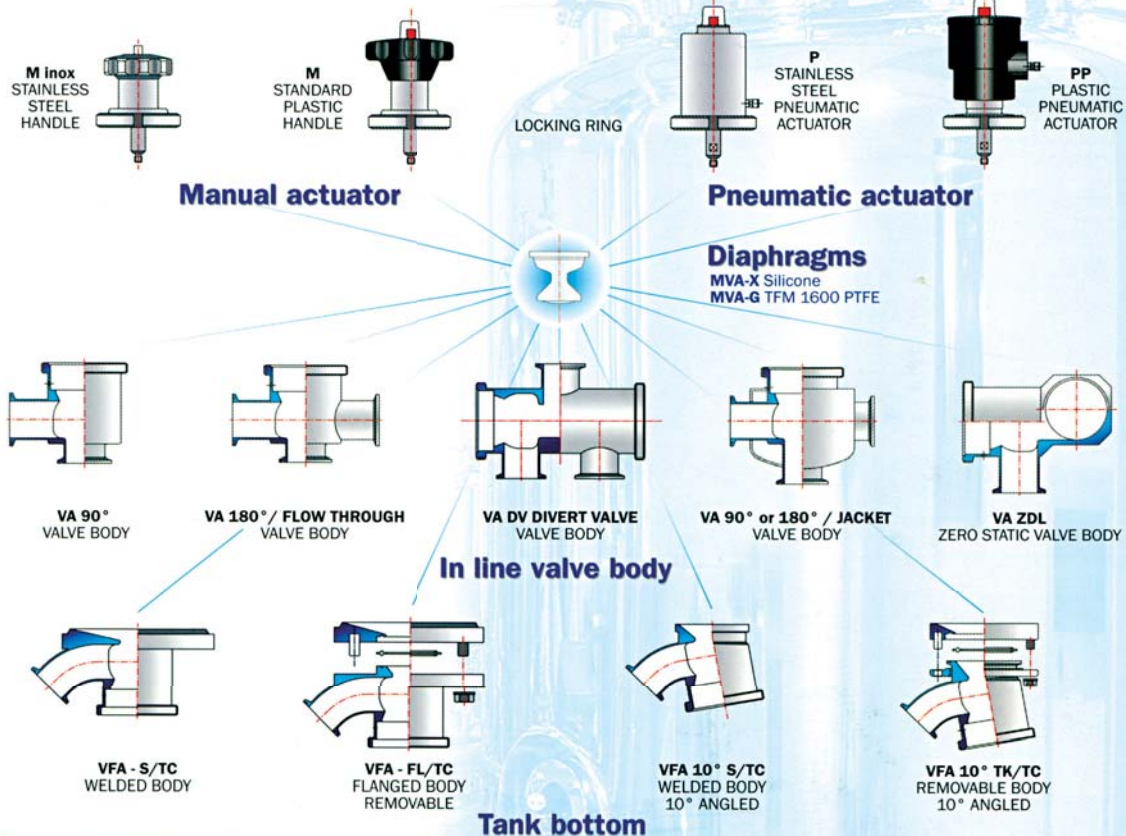



**VPA - VPAK**  
ASEPTIC SAMPLING VALVES



**RPS**  
SANITARY SAMPLING VALVES



**SSB**  
SANITARY SAMPLING BOTTLE



**VA - VFA**  
TANK BOTTOM VALVES



**VRN**  
SPRING CHECK VALVES



**VSS**  
HIGH PURITY BALL VALVES



**VF**  
BUTTERFLY VALVES



**HE**  
DTS HEAT EXCHANGERS



**SP - SL**  
SIGHT GLASS-FLOW INDICATOR



**TC**  
CLAMP FITTINGS



**TK - CONN**  
TANK CONNECTIONS

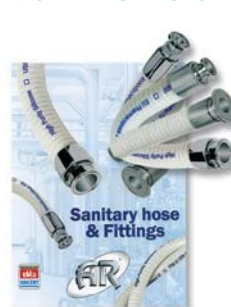

**RE - FLEX**  
SILICONE HOSE & FITTINGS



**MM**  
MAGNETIC MIXER



**DD**  
REPLACEMENT DIAPHRAGMS



**RSH**  
ROTATIVE SPRAY HEAD



**Sanitary  
flow  
equipment**

**AERRE INOX s.r.l.**  
Lottizzazione Gerola  
I-26010 Fiesco (Cremona)  
Tel. +39 0374 370 828 - Fax +39 0374 370 833  
[www.aerreinox.it](http://www.aerreinox.it)

Get the information you need and more at [info.aerreinox.it](http://info.aerreinox.it)