



High purity ball valves



HIGH PURITY BALL VALVES

■ FULL PORT

The VSS ball valves are engineered to be a true process piping component to specifically meet the demanding processes found in pharmaceutical industries.

Three pieces ball valve are machined from solid round bar in AISI 316L (1.4404 – 1.4435) and put quality and reliability into your process.

The VSS ball valves are a full bore / full port design according to ASTM A 269 dimensions, the tube-ID port opening is dimensionally identical to the adjacent tubing to comply with ASME-BPE Guidelines;

Full bore / full port design minimizes line turbulence and pressure drop.

■ SIZE RANGE

Model VSS...-TC – clamped from ½” up to 4” - Tube OD (2 way)

Model VSS...-SS – butt weld from ½” up to 4” - Tube OD (2 way)

Model VSS...-TB/BW – tank bottom flush weld from ½” up to 2”

Model VSS...-TB/TK – tank bottom TK-Conn removable
from ½” up to 2”

■ END CONNECTIONS

Interchangeable end caps are available for different applications.

Completely machined from bar, no welded tube extension clamped – BS 4825

butt weld – Tube OD, or extended tube weld for orbital welding

■ SURFACE FINISH

Internal body surfaces 0,5 micron Ra or better

External mirror polished.

Enhanced surface finishes and electropolished valves also available on request.

■ SEAT MATERIAL

TFM 1600 PTFE cavity-filled complying with FDA

guidelines and USP Class VI, is standard on VSS

Cavity filled seats are not suitable for steam service.

For more information on the seat characteristics please contact us

■ OPERATOR

The valve can be fitted with manual handle or with ISO NAMUR mounting pad for pneumatic actuators
Stainless steel manual handle (quarter-turn for open/close)
Pneumatic actuator (DA double acting – SR spring return)

■ MARKING

To guarantee full traceability, following information will directly be marked on the valve body :

AR logo (identif. constructor) - code, material and size – max. operating pressure (30 bar) – CE Mark (when necessary) – internal code es. 0605 1623 where 0605 indicate year and month manufacturing and 1623 indicate our internal order confirmation.

Additional information such as customer tag number is available upon request

■ PRESSURE / TEMPERATURE RATING

Minimum / Maximum working pressure Vacuum / 30 bar g

Minimum / Maximum working temperature -10 °C / 150 °C

For equipment in compliance with the European Directive 97/23/CE “PED” DN>32

The mark **CE** indicates product compliance with the new approach community directives for better harmonising member state legislation. Declaration **CE** of conformity according to evaluationform “A” (ENCLOSURE VII European Directive 97/23/EC)
The VSS equipment meets the basic requirements indicated in Directive 97/23/CE



For equipment in compliance with the European Directive 94/9/CE ATEX II2G-D T4

Specific and supplementary mark according to Directive 94/9/CE ATEX indicating in order the specific symbol for the explosive. The unit number and the category to which it belong, the type of atmosphere in which the product can be used and the temperature class.
Declaration **CE** of conformity according to evaluationform “A” (ENCLOSURE X European Directive 94/9/EC ATEX)
The VSS equipment complies with the basic requirements indicated in Directive 94/9/CE

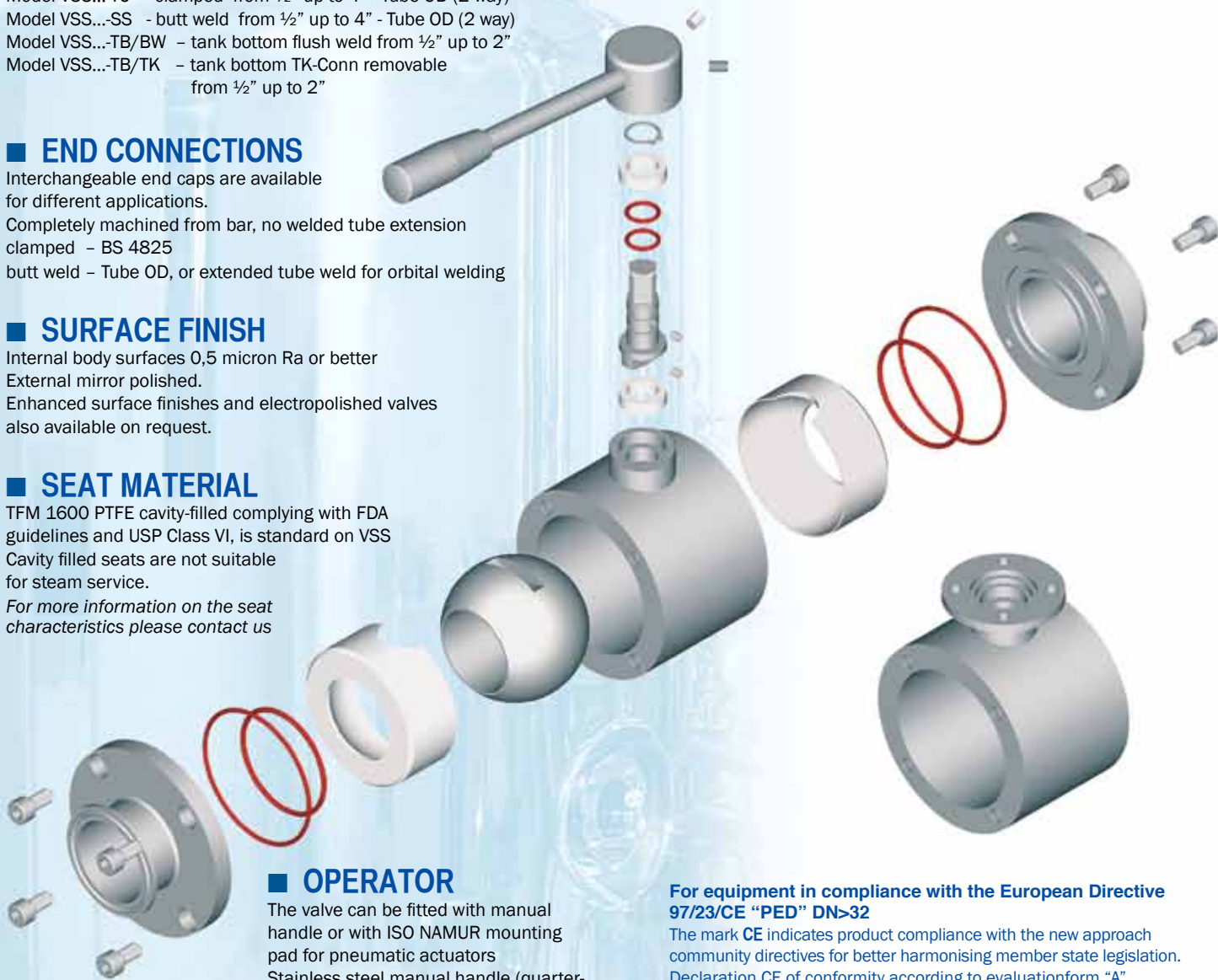

TFM™ AS A SEATING MATERIAL FOR HIGH PURITY VALVES

AR Inox High Purity ball valves utilize Dyneon™ TFM 1600 PTFE as a standard seating material.

What is TFM™ ?

TFM is chemically modified PTFE that fills the gap between conventional PTFE and melt-processable PFA. According to ASTM D 4894 and ISO Draft WDT 539-1.5, TFM is classified as a PTFE. TFM-PTFE is a second-generation modified polytetra-fluoro-ethylene (PTFE) that maintains the exceptional chemical and heat resistance properties of conventional PTFE, but with significantly lower melt viscosity. This property results in better particle fusion during sintering and much smoother ball-to-seat sealing surfaces.

TFM 1600 PTFE are ideal for ball valves in high purity applications. In addition, TFM complies with :

- 3A Sanitary standard for multiple-use plastic materials used as product contact surfaces for dairy equipment.
- FDA-21 CFR 177.1550 direct contact with meat or poultry food products prepared under FDA inspection.
- USP23, biological test for plastic Class VI



**cavity filled seat
TFM 1600 PTFE
for high purity
applications**



**TFM 1600 PTFE
for steam service**



Ordering information

To specify the part completely, start with the product description and select the additional options as shown below:

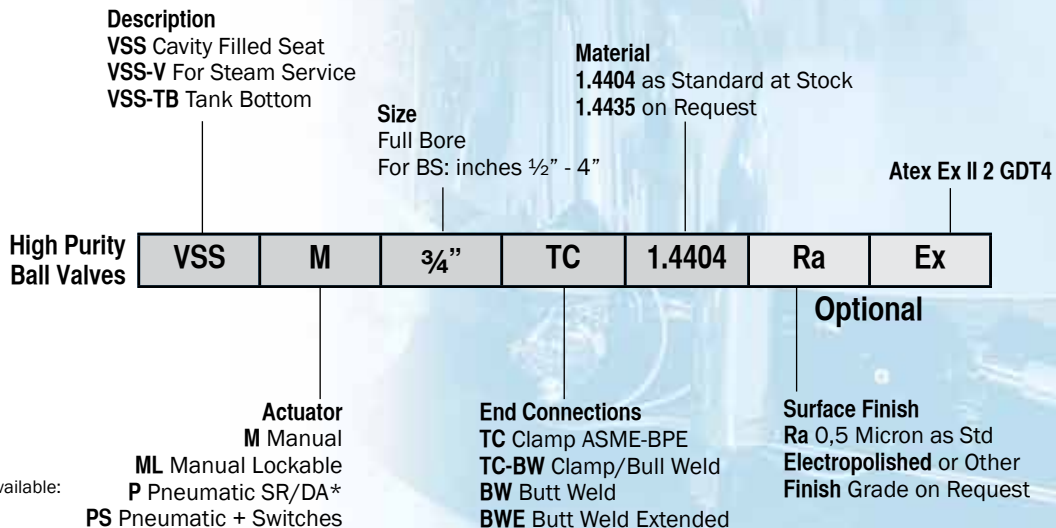

* Pneumatic Actuators Available:

- AL Anodized Aluminium
- AT PTFE Coated Aluminium
- SS Stainless Steel

VSS-TB-BW TANK BOTTOM BALL VALVE WELDED BODY

Application:

The "TB" Series Flush Tank ball valve incorporates all the advantages of VSS. Available in different executions, may be fit at the tank bottom by welding plate or TK-Connection; for special applications on existing reactors, we also manufactures special adaptor plates in order to accommodate customer request.

The special design of the welding plate, is an integral welded part of the tank surface and preventing stagnation of the media.

Benefits over conventional Flush Tank Valve:

Valve mounts flush with the inside vessel wall, minimizing dead space
Angle stem allow actuator clearance on jacketed or insulated tanks
Higher CV with full bore, no pressure drop
Simple quarter-turn opening

Standards:

The VSS-TB-BW ball valve is a process accessory to be used for clear or viscous liquid products from group 2 in accordance with European pressure equipment directive PED 97/23/CE are CE compliant under the SEP "Sound Engineering Practice" (Article 3 - Paragraph 3)

Operating conditions:

Minimum /max working pressure Vacuum / 6 bar g
Minimum /max working temperature -10 °C to 150 °C

Special executions available on request: Welding plate with radius or bigger different thickness, extended tube for orbital welding. For special applications, we manufactures special adaptor plates, when replacing a conventional flush tank valve, with a flush tank ball valve and also to ship the plate independently from the valve, in order to accommodate customer requests.



MANUAL

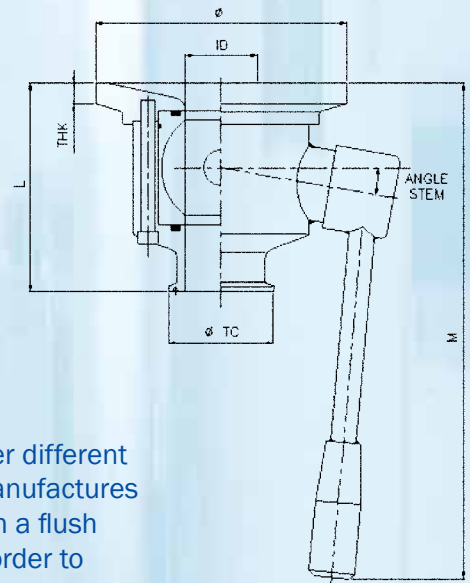

PNEUMATIC

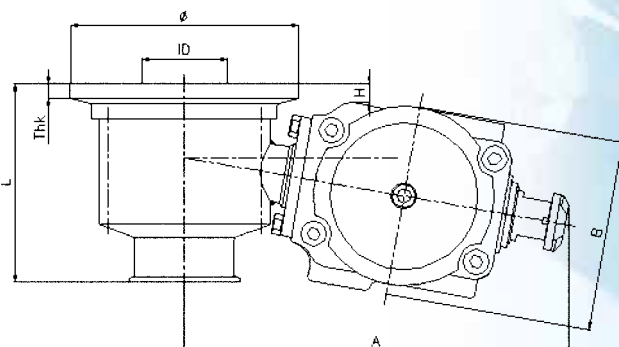

FEATURES

1 BODY

Three-Piece Sanitary design enables in-line maintenance of ball valve. Full flow body design minimizes line turbulence and pressure drop through the valve.

2 END CONNECTION

Clamp end connections are self-aligning for fast, easy takedown and reassembly without tools. Butt-weld end connections also available for dependable service in permanently installed pipelines.

3 BODY BOLTING

Body bolting in 304 Stainless Steel permits easy assembly/disassembly.

4 BALL

Precision machined from solid bar and polished to a mirror finish for bubble tight shut-off. Each ball is designed to have minimum torque and provides high life cycle.

5 STEM

Stem and packing design eliminates possibility of stem becoming dislodged or blown out. Designed for installation of handle for manual operation or for direct mounting of pneumatic actuator that meets ISO 5211 specifications.

6 ANTISTATIC DEVICE

To eliminate possibility of static electrical charges within the valve, two grounding connections are set in the stem to ensure electrical continuity for the entire ball valve.

7 HANDLE

Ball valves fall under the general category of "rotary valves": quarter-turn for open/close. Handle gives visual indication of flow with stop lug.

8 MOUNTING PAD

A set of ISO 5211 mounting patterns are available to accommodate a range of pneumatic actuators. Machined flat surface ensures correct alignment of actuator to the stem top for minimum side loading during operation.

9 BALL SEAT

Various seat materials and executions are available for different applications. Standard: TFM 1600 PTFE cavity-filler seat are intended to prevent the build up of product that may when entrapped between the ball and body cavity-solidify or otherwise inhibit the smooth operation of the valve closure member on critical process applications. The valves used in steam service (24 hours continuously) should not utilize this seat arrangement.

10 STEM SEAT

Two o-ring in Viton and two stem guide in 25%Glass Fiber filled PTFE ensuring sealing integrity of the stem.

11 BODY SEAT

Two o-ring in Viton for each end connections ensuring sealing integrity of the valve body.

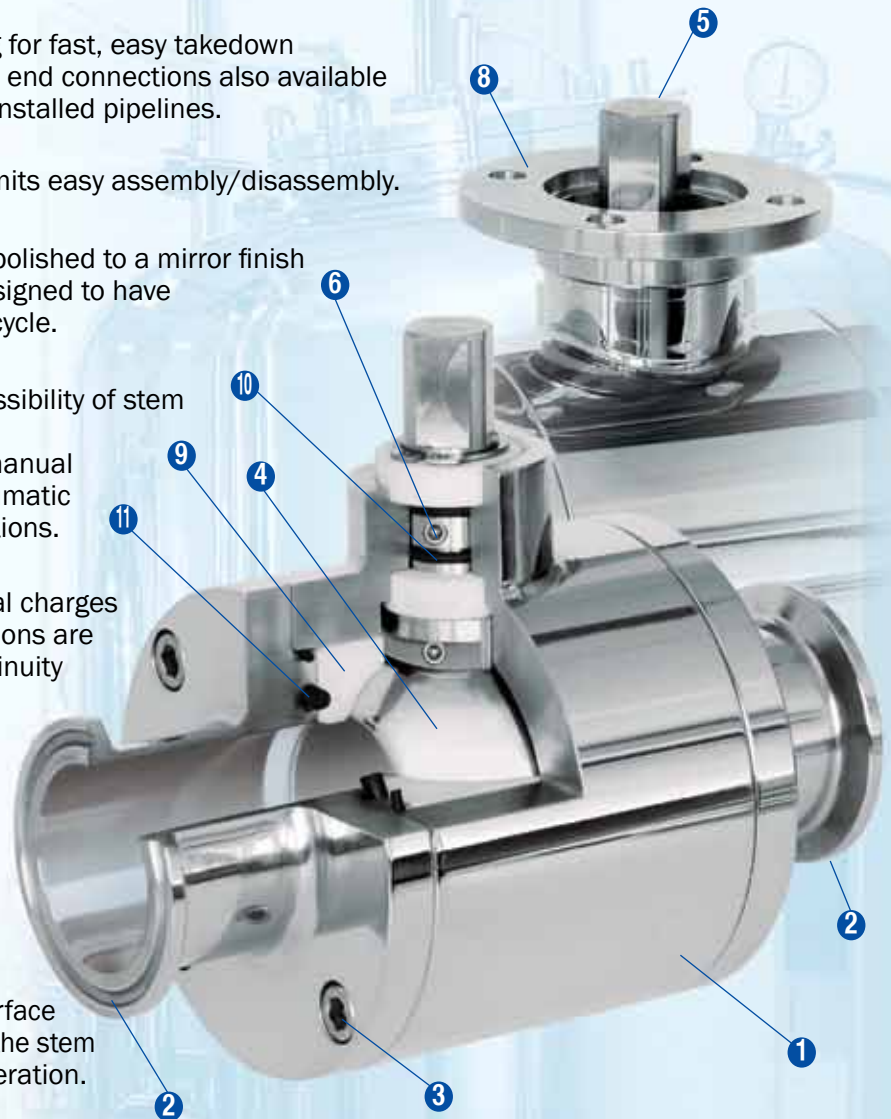

BENEFITS

Ball valves are well proven in the most rigorous applications. Some key advantages of the design includes:

- Economical compared to most other valves design
- High flow rate through an unobstructed flow path
- Quick, quarter-turn operation
- Easy to automate pneumatically
- Inherently flexible to meet a wide range of pressures and temperatures
- Simple maintainability
- Self-flushing design

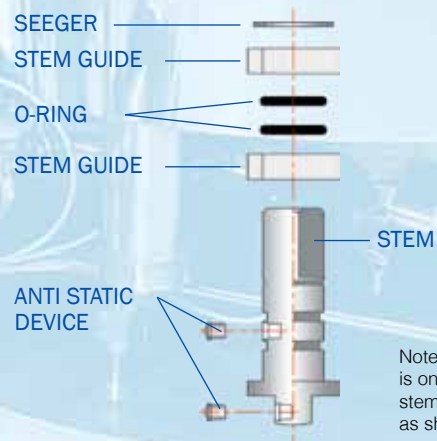

Note: Anti-static device for 1/2"-3/4" is on the side and bottom of the stem. For other sizes, is located as shown in the drawing.



Sanitary flow equipment

AERRE INOX s.r.l.
Via Gerola, 4
I-26010 Fiesco (Cremona)
Tel. +39 0374 370 828 Fax +39 0374 370 833
www.aerreinox.it

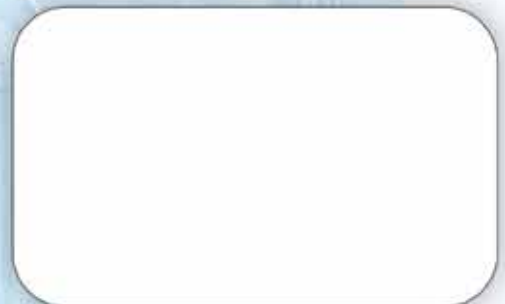

Get the information you need and more at info.aerreinox.it