

Available Configuration

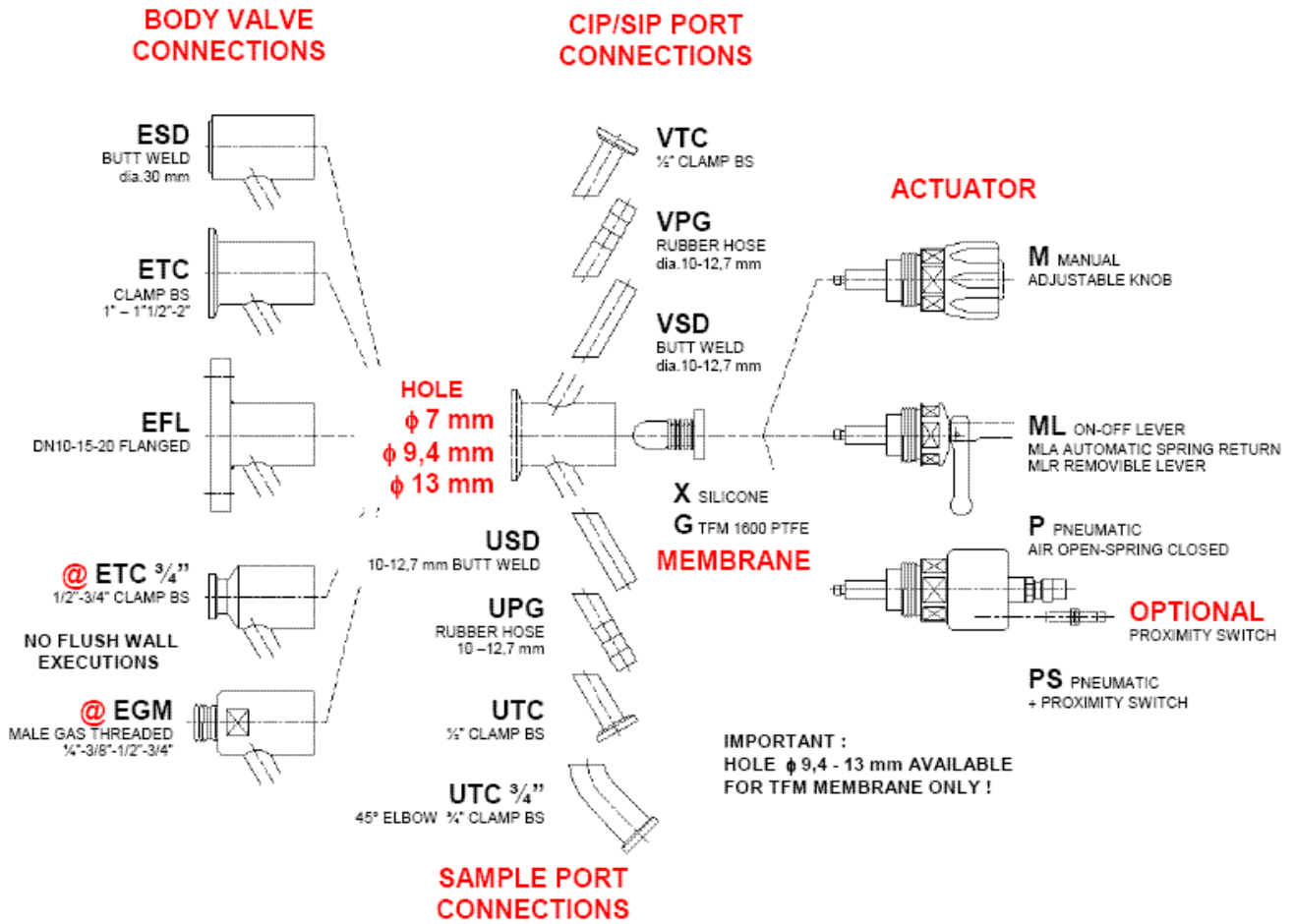

Ordering information

To specify the part completely, start with the product description and select the additional options as shown below :

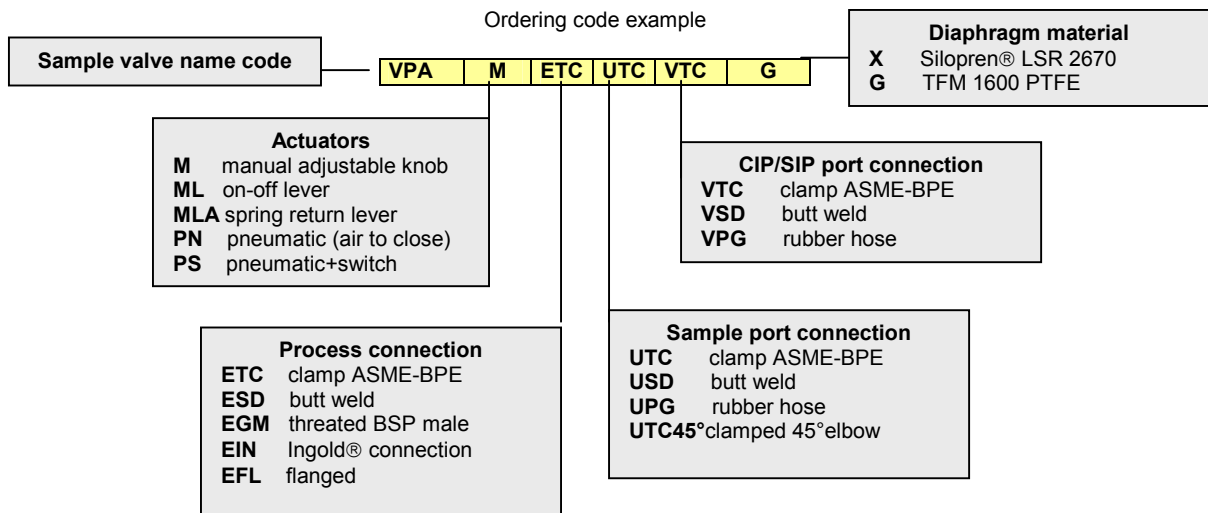

VPA - PTFE Diaphragm

Technical specification

TFM 1600 PTFE diaphragm are obtained, by means of machining on CCN, from **TFM™ 1600 PTFE** bar, Poly-Tetra-Fluor-Ethylene from Dyneon™- 3M. compound are manufactured conforming to the following norms :

- FDA Code of Federal Regulation
- CFR under title 21, paragraph 177.1550
- U.S.Pharmacopoeia Class VI

Maintenance :

TFM 1600 PTFE diaphragm must be replaced once every year, but in the event of intensive use, sterilisation and cleaning it may be necessary to replace it more frequently.

AR-Inox guaranties one year of lasting by normal use means

(silicone has to be changed approx every 4-5 months)

Temperature.....121°C (150°C for short period only)

Steam pressure.....1,5 up to 2 bar max.

At higher pressures the membrane can be damaged

Remember ! use saturated steam without condensation only

Process pressure.....6 bar max.

Sample.....1-5 a day

Chemical resistance : Is not attacked by common chemicals

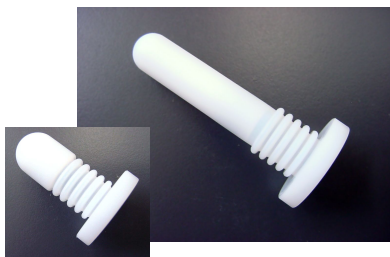

TFM 1600 PTFE			
Ordering code	MVPA-G		
Material	TFM 1600 PTFE		
Colour	White		
Powder compound properties			
Property	Value	Unit	Test Method
Bulk density	830	g/l	ASTM D 4894-98a
Average particle size	450	μ	ASTM D 4894-98a
Mechanical properties, measured at 23°C (73°F)			
Tensile Strength	4600	psi	ASTM D 4894-98a
Elongation at break	450	%	ASTM D 4894-98a
Specific gravity	2.16	g/cc	ASTM D 4894-98a
Shrinkage	3.5	%	ASTM D 4894-98a
Tensile Modulus	94,250	psi	ASTM D 638
Deformation under Load		%	ASTM D 621
2175 psi – 24 hrs	8		
2175 psi – 100 hrs	9		
2175 psi – permanent	4		
Thermal properties			
Flammability	V-0		UL94
Melt point (initial)	342 ±10	°C	ASTM D 4894-98a

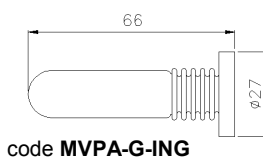

code **MVPA-G-ING**

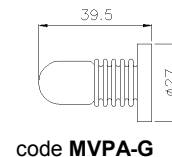

code **MVPA-G**

VPA - SILICONE Diaphragm

Technical specification

Build by **Silopren® LSR 2670** a silicone elastomer composed from two components, it is supplied by GE Bayer Silicones and it is obtained with a modern system of injection molding.

After molding, they under go a heat treatment (post-cured) of 4 hours at 200°C inside a furnace with forced ventilation.

All diaphragms are manufactured in 100% silicone of medical grade conforming to the following norms:

- FDA Code of Federal Regulation
- CFR 177.2600
- U.S. Pharmacopoeia Class VI

Maintenance :

Average live of a silicone diaphragm is 4-5 months of lasting by normal use means

Temperature max.....121°C

Steam pressure.....1,5 up to 2 bar max.

Process pressure.....6 bar max.

Sample.....1-5 a day

not recommended for use with alcool, solvent, glicerina

Silopren LSR 2670	
Ordering code	MVPA-X
Material	Silopren® LSR 2670
Colour	White
Hardness	60 Shore
Tensile strength	10,5 MPa
Wear resistance	Less suitable
Tear resistance	Very good
Resistance to Weather and Ozone	Excellent
Resistance to Hydrolysis (water and steam)	Good
Resistance to Chemicals (acids / bases)	Suitable
Resistance to mineral oil and gas	Less suitable
Air and Gas density	Not suitable

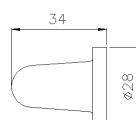

code **MVPA-X**

WARNING !

THE INSPECTION CHECK AND MAINTENANCE INTERVALS CAN DEPENDS FROM OPERATING CONDITIONS AS TEMPERATURE, PRESSURE AND FLUID TYPE HOWEVER, ALWAYS REMAIN TO THE USER, THE RESPONSABILITY TO FIX A SUITABLE PROCEDURE WITH THE INTERVALS AND FORMALITY IN ORDER TO REPLACE THE DIAPHRAGM BASED ON OWN EXPERIENCE.